

# MODULAR TEST ENVIRONMENT FOR FUEL CELL-BASED ELECTRIC POWERTRAINS FOR AVIATION: METHODOLOGICAL APPROACH OF THE BALIS TEST FIELDS FUEL CELL, BATTERY AND E-DRIVE

Jörg Weiss, David Diarra, Kai Sommer, Bing Ni, Oliver Thalau, Cornelie Bänsch

German Aerospace Center (DLR), Institute of Engineering Thermodynamics  
Pfaffenwaldring 38-40, 70569, Stuttgart, Germany  
Tel.: +49 711 6862-8325  
cornelie.baensch@dlr.de

## Abstract

The application of fuel cell technology for all-electric-aircraft is currently driving numerous research activities as a disruptive approach to achieve decarbonization of short-range and regional aircraft. For the CS-23 class, the feasibility of fuel cell-based all-electric aircraft has already been demonstrated. Recently, several attempts were communicated to upscale the technology to the CS-25 class with the goal to achieve a megawatt demonstration on ground and in flying test platforms.

The aim of the BALIS test infrastructure is the experimental investigation of powertrain subsystems fuel cell, liquid hydrogen tank, battery, and electric drive in the megawatt scale on ground. Following a modular approach, the named subsystems are integrated in particular test fields, which can be operated separately or coupled flexibly via the infrastructure. This approach enables the investigation of upscaling and coupling phenomena under application-relevant load profiles. After being developed and built over the past three years, this work focusses on presentation of the test fields fuel cell, battery and e-drive as well as the corresponding high voltage electrical system of the BALIS facility. The electric coupling between the test fields is carried out with the so-called switch matrix. The switch matrix enables a flexible realization of different use cases embodied by different electric connection schemes in order to investigate the electrical interactions between the subsystems, the optimization of components and operation strategies. The methodological approach is presented and an outlook on the scope of scientific research is given.

## 1. INTRODUCTION

In order to achieve the climate action goals of the International Air Transport Association (IATA) [1] fuel cell-based electric propulsion is one approach for emission reduction of regional aircraft [2,3]. In several flight demonstration projects, the feasibility of the application in manned aircraft has already been proven for CS-23 class [4-10]. In all named projects polymer electrolyte membrane fuel cell (PEMFC) technology was selected. PEMFC offer a high technological maturity and beneficial power density compared to other fuel cell types [11-13]. Recently, several attempts were reported by the industry to upscale the PEMFC technology to megawatt (MW) power aiming for the application in CS-25 class [14,15]. However, to the best of the authors' knowledge no evaluation of the concepts, results or fundamental findings from these projects has been published. Scientific studies are available for the MW operation of PEMFC systems for stationary application [16-19]. However, the design approach does not meet the aviation requirements and no interaction in an electric propulsion system including electrical system and e-drive is considered. Overall, no experimental studies for the operation of MW PEMFC-based powertrains for aircraft application are available yet. To bridge this gap, a multi-integrative test environment of the same name was designed in the project BALIS following a system engineering methodology [20]. The aim

is to develop and investigate the subsystems of PEMFC-based powertrains and their coupling behavior under application-relevant load profiles with the test facility. Ultimately, fundamental knowledge about the MW operation should be gained and the scalability of the technology to the CS-25 class should be evaluated. After being built-up in the past years, the test fields for fuel cell and electric motor as well as the electric infrastructure including battery emulator are now available. In this work, the methodological approach of these test fields with the integrated first-generation test system is presented and a discussion of the first commissioning test results is given.

## 2. CONCEPT OF THE BALIS TEST ENVIRONMENT

The principle concept of the test environment has already been presented in ref. [20]. The characteristic feature of the setup is the modular approach. According to this approach the test environment is divided into different test fields for each powertrain subsystem, namely:

- Fuel cell test field
- Electric motor test field
- Battery test field
- Liquid hydrogen (LH2) test field

In each test field the devices under test (DUT) are integrated, representing the different subsystems of the electric powertrain.

This work focusses on the fuel cell and electric motor as well as the evaluation of the role of the battery. The BALIS infrastructure enables the testing of these DUTs separately and in different electrically coupled configurations using the centerpiece of the electrical infrastructure, the so-called switch matrix, which is schematically depicted in Figure 1. Load simulation is carried out by using three separate direct current (DC) source/sink modules (AVL, 1250 A / 825 kW). They are connected to the power distribution units of the different test fields with the switch matrix via common high voltage (HV) DC busses. By activating or deactivating the different switches of the switch matrix (red dots in Figure 1), different use cases can be realized representing different interconnection configurations between the test fields and the DC source/sinks. Sixteen of these use cases are provided in the current switch matrix concept. With this approach isolated tests in the different test fields as well as direct and parallel interconnections are possible. Surplus energy is fed back into the grid. A detailed overview is given in ref. [20].

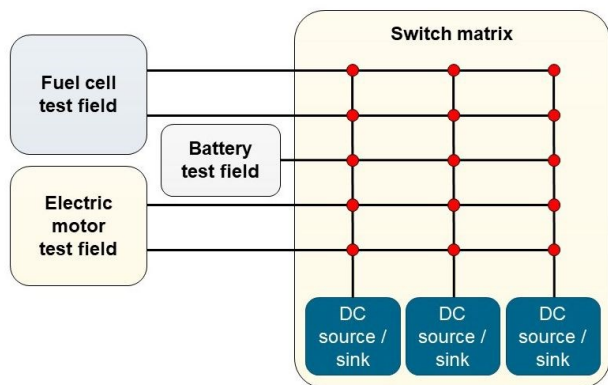

**Figure 1** Schematic diagram of the BALIS switch matrix, the connected test fields, and DC source/sinks; The switching options enabled by the switch matrix are indicated by the red dots with the possibility of realizing 16 pre-defined use cases.

### 3. POWERTRAIN SUBSYSTEMS

The basic idea of the BALIS test fields is to provide a flexible test infrastructure for the development and testing of powertrain components and subsystems in cooperation with system developers. In target-oriented projects the major challenges for the implementation of fuel cell-based powertrains in regional aircraft applications like weight reduction, robust operation and cycle stability should be addressed. In the framework of the BALIS project, a first-generation powertrain system was designed, procured and integrated. The system consists of off-the-shelf products aiming towards aircraft requirements. Nevertheless, as the system is no flightworthy hardware it should rather be seen as a first benchmark system for the MW operation. In the following sections, an overview of the powertrain and integration concept of the first-generation system is given.

### 3.1. Fuel Cell System

#### Overview

Achieving MW power with PEMFC systems is currently only possible by connecting several PEMFC stacks at least electrically [21,22]. For the first-generation BALIS PEMFC system 12 commercial fuel cell modules (PS-100, PowerCell,  $P_{gross}=120$  kW,  $P_{net}=100$  kW ) consisting of the PEMFC stack and a complete balance-of-plant (BoP) system including control unit are connected leading to a maximum theoretical net output power of 1.2 MW. For each module a test space is provided equipped with media supply and the connection to the electrical, control and exhaust system. An overview of the system architecture of the multi-stack configuration is shown in Figure 2. In the following, the electrical and fluidic architecture of the DUT system and the fuel cell test field is described.

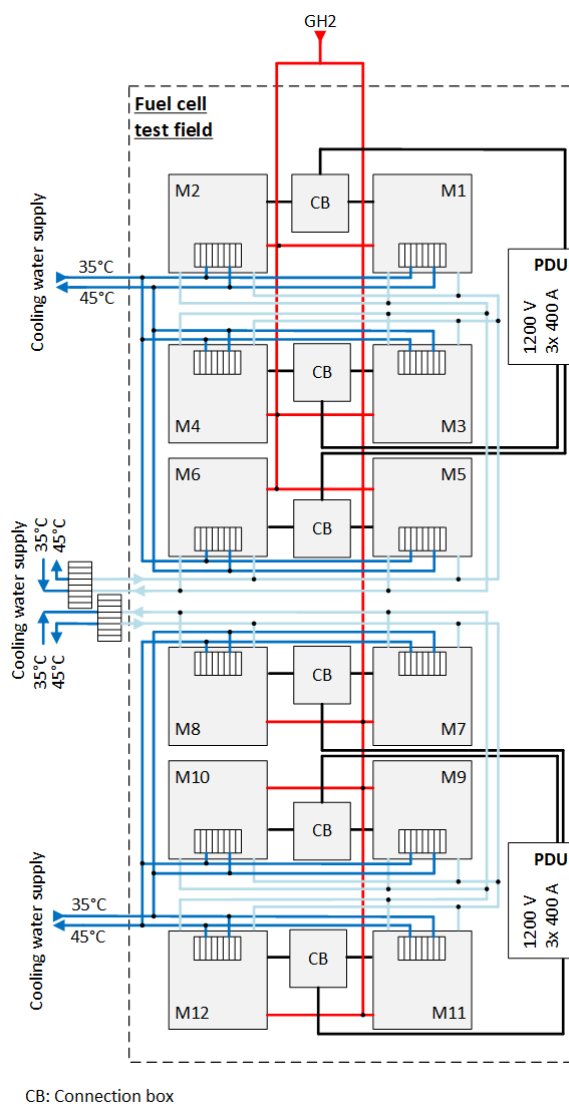

**Figure 2** Overview of the system architecture of the BALIS 1<sup>st</sup> generation fuel cell system integrated into the fuel cell test field; The numbers M1...12 denote the different fuel cell modules; dark blue: cooling water circuit, light blue: cold water circuit, red: hydrogen supply, black: HV DC system; The air supply and exhaust system is not depicted.

## Electrical Architecture

Two fuel cell modules respectively are connected in series to form one fuel cell string adding their cell voltage to the total output voltage  $U_{out}$ , while the output current  $I_{out}$  is equal for both modules. The series connection is realized with a connection box (PowerCell), which contains the switches and pre-charge devices for connecting and disconnecting the string. Three strings are connected in a direct parallel configuration via one copper busbar in the power distribution unit (PDU) of the infrastructure. Hence, the string voltages are fixed at the same voltage level represented by the bus voltage, while the overall PDU output current equals the sum of the string currents. Two PDUs (AVL, 1200 V / 3x 400 A, 750 kW) for fuel cell testing are available. Beside the busbar for fuel cell connection the PDUs are equipped with fuses, optional diodes and disconnectors required for safe operation. In the baseline concept of the first-generation fuel cell system both PDUs and thus two 3x2 fuel cell system are in turn connected in a direct parallel configuration via the switch matrix. Altogether, a 6x2 (parallel x serial) configuration of the multi-stack fuel cell system is realized with all string voltages fixed on one bus voltage. Auxiliary power supply is realized via the low voltage supply of the infrastructure. CAN communication is used for the connection of the fuel cell string controller with the overall control system. The two modules of one string are controlled in a master/slave operation mode. An ethernet connection serves for diagnosis and software updates.

## Fluidic Architecture

Ambient air is supplied to the fuel cell modules through the air inlet infrastructure of the test field in a parallel configuration. Each fuel cell module is equipped with an air supply module including single-stage compressor and humidification unit. Hence, the air inlet infrastructure is designed passively without any additional blower or compressor. Hydrogen is supplied from a hydrogen trailer, which contains 20 m<sup>3</sup> hydrogen at 200 bar at the maximum filling level (Air Liquide, Hydrogen N50, purity: ≥99.999 vol%). The hydrogen supply system consisting of pressure reducer, purging system, safety valves and piping is designed in a way that hydrogen can be supplied to the fuel cell modules within their back-pressure operating window between 5.5 and 16 bar in any operational mode with an overall hydrogen flow of up to 120 kg/h. The hydrogen supply for all modules is realized in a parallel configuration. Cathode and anode exhaust are released jointly through one passive exhaust venting system. The operation temperature of the fuel cell modules is in a range between 65 and 80°C. For the thermal management of the FC stacks each module is connected to the cooling-water circuit ( $T_{in} = 35^\circ\text{C}$ ,  $T_{out} = 45^\circ\text{C}$ ) via a heat exchanger. The primary cooling of the stacks is achieved with a dedicated FC coolant (BASF, Glysantin FC G20) and controlled by the FC module controller. The BoP components are cooled via the cooling-water circuit of the facility as well.

## 3.2. E-Drive System

### Overview

High power as well as high volumetric and gravimetric power density are the main requirements for electric motors for all-electric aircraft. Among the available state-of-the-art motor technologies permanent magnet synchronous machines (PMSM) are currently seen as the most suitable option for aircraft applications [23,24]. For the first-generation BALIS e-drive system two high-speed PMSM (Compact Dynamics, 600 kW<sub>max</sub>/500 kW<sub>continuous</sub> @ 17,000 rpm) are coupled mechanically via a gearbox. The motors exhibit a high specific power of 13.9 kW/kg<sub>continuous</sub>. (Note, that for an assessment of the whole e-drive weight the mass of reduction gear also has to be considered). An overview of the electric motor test field architecture is shown in Figure 3. The electrical, mechanical and fluidic architecture is described in the following sections.

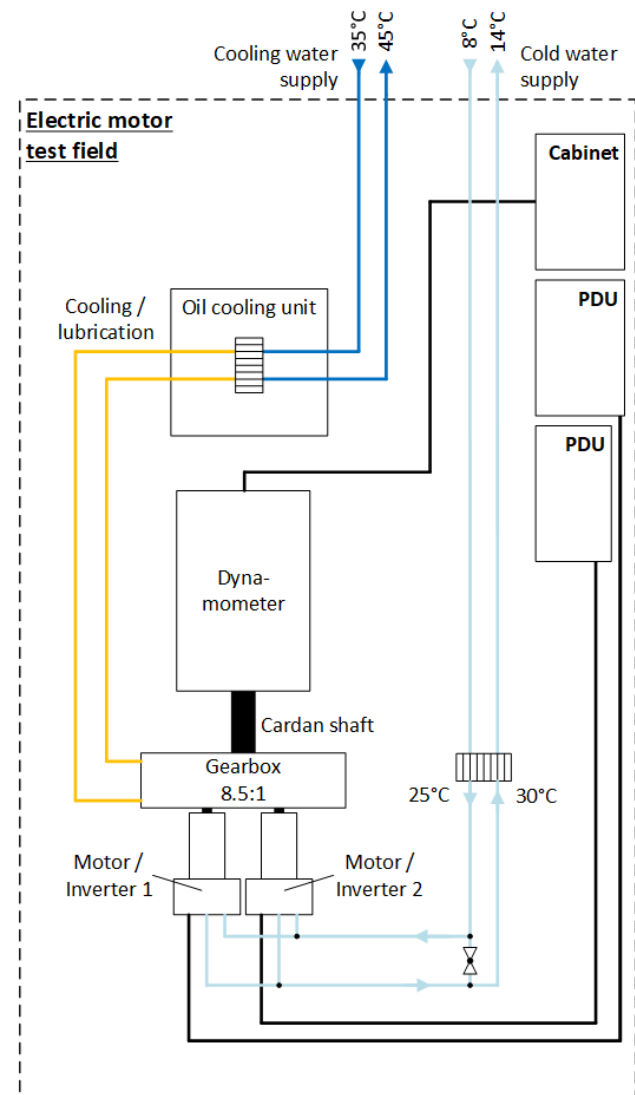

**Figure 3** Overview of the system architecture of the BALIS 1<sup>st</sup> generation e-drive system integrated into the electric motor test field; dark blue: cooling water circuit, light blue: cold water circuit, yellow: oil cooling circuit, black: HV DC system.

## Electrical Architecture

For the high voltage DC supply each inverter is connected to one PDU (AVL, 1200 V / 1250 A, 750 kW) as part of the test field infrastructure, respectively. The control of the e-drive is achieved via CAN communication. For diagnosis, calibration and software-update the motor/inverter unit is equipped with an ethernet connection. For auxiliary power supply their controllers are connected to the test field low voltage supply.

## Mechanical and fluidic Architecture

Mechanical coupling of the motors is achieved with a summation gear (Chemnitzer Zahnradfabrik, >98% efficiency, 210 kg). In order to achieve an application relevant speed range a transmission ratio of 8.5 was applied. A cardan shaft connects the transmission output shaft with the dynamometer. The motors/inverters operate at cooling water feed temperature of 25°C. For the thermal management of the motors, the primary cooling loop is connected to the cold-water cooling circuit of the infrastructure. Cooling water is used for heat release of the gearbox, which is equipped with an oil cooling as primary cooling loop.

### 3.3. Role of the Battery

The HV DC power management in fuel cell-based electric powertrains is a challenging task due to limited dynamic performance of the fuel cells, ripple currents and electrical oscillations in the HV system (see e.g. ref. [25]). In addition, powertrain efficiency and weight can potentially be optimized by load sharing with buffering systems. As a consequence, the application of additional auxiliary storage systems based on batteries can be necessary or beneficial (see e.g. ref. [26]). As a result, the application of battery systems in fuel cell-based aircraft propulsion systems has already been demonstrated in the CS-23 class [4,7]. The disadvantage of the application of batteries is their poor specific energy density, why oversizing of an auxiliary battery system has to be avoided. As a consequence, the optimal sizing and design of an auxiliary battery system is highly dependent on the load profiles as well as the system architecture and specifications. In order to provide the possibility for the investigation of the role of batteries in the propulsion system the DC source/sink can also serve as a battery emulator. Real batteries can be investigated in the BALIS battery test field. The infrastructure for this test field is already finalized allowing the coupling of battery systems with the HV electrical system via a PDU (AVL, 1200 V / 1250 A, 750 kW) and the switch matrix. No battery test chamber or physical battery system has been integrated yet. The aim is to gain more profound understanding of the requirements and sizing of auxiliary battery systems by emulating the battery behavior in a first step.

### 3.4. Commissioning Testing

First commissioning testing has been carried out with the fuel cell system and the e-drive system. In a first step stationary tests were conducted for proving performance stability of the DUTs under part load. The stationary load scenarios were simulated by the infrastructure without coupling of fuel cell and motor performance.

In the case of the fuel cell system galvanostatic experiments were conducted, varying the current request stepwise and measuring the fuel cell performance at a stable current for a few minutes. At first, the strings were tested separately. Each string showed a stable performance over the whole power range. The maximum power of the strings at 400 A output current differed by 7 kW ranging from 215 to 222 kW. In the next step the direct coupling of 3 and 6 strings, respectively, was achieved simulating the load via one DC source/sink module. The experiments were conducted in the load following mode, where the set point of the FC module BoP is gathered from the actual current that is drawn. Only moderate dynamic can be realized in this operating mode to prevent any violation of operational limits. Measuring data of a stationary test with 6 coupled strings is shown in Figure 4. A stable power output can be observed between 200 and 590 kW. Further tests were conducted coupling 3 strings only. During all coupled tests load oscillations between the parallel connected strings were observed. In case of the 3 string experiments, the oscillations reached a maximum amplitude of 22 A at a total current of 600 A. Smaller values were observed during the 6 string tests. It is assumed that these oscillations can be avoided by the implementation of an adapted control strategy. However, a detailed discussion of the occurrence of oscillations is beyond the scope of the present work and will be evaluated in future studies. Overall, a proof of the part load performance of the 6x2 multi-stack fuel cell system could be achieved.

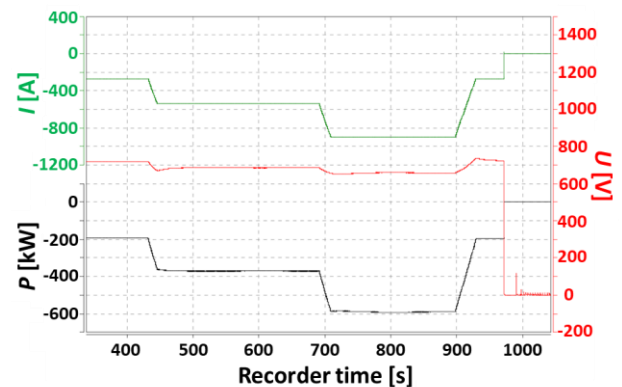
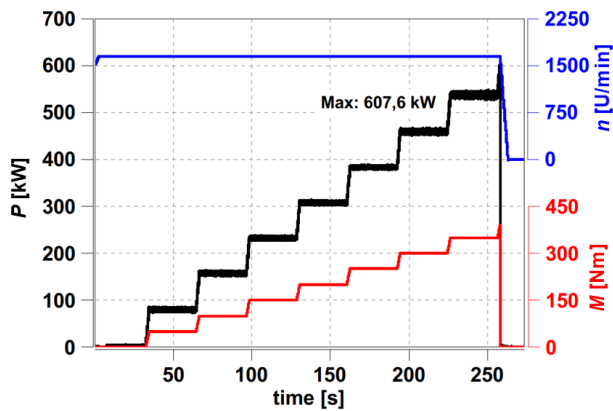

**Figure 4** Measuring data of a stationary experiment with the 6x2 multi-stack fuel cell system varying the power between 0 and 590 kW; green: current, red: voltage, black: power. The test was conducted as a galvanostatic experiment controlling the fuel cell system in the load following mode.

In the case of the e-drive system single- and dual-motor tests were conducted. As the dynamometer has not been finally parametrized yet it cannot be operated at full power by now. Hence, maximum power tests with one motor and part-load tests with two motors were conducted. Measuring data of a single-motor test is shown in Figure 5. A stable power output can be observed in the whole power range between 0 and 600 kW. Above 600 kW the control system shut down automatically due to the preliminary implemented operation limits. In the dual-motor experiments the two motors were operated together coupled via the gearbox. A shaft power of up to 200 kW could be achieved. In all cases pronounced oscillations of the torque at the main shaft of the gearbox occurred, while



only minor vibrations of the gearbox were observed. It is assumed, that the final parametrization of the dynamometer reduces these oscillations. For a detailed evaluation of this effect further testing is required. Altogether, a first commissioning of the electric motor test field with the single-motor experiment could be achieved.



**Figure 5** Measuring data of a stationary experiment with one electric motor varying the power between 0 and 600 kW; red: torque at the dynamometer, blue: rotational speed, black: power. The test was conducted by controlling the torque at the dynamometer at constant rotational speed of 1650 rpm.

#### 4. CONCLUSION AND OUTLOOK

The upscaling of fuel cell-based electric aircraft propulsion into the MW range and their proof of performance is a technological challenge, which has rarely been tackled yet. The BALIS test environment has been developed to enable the experimental investigation of such powertrains of up to 1.5 MW power. Following a modular approach, the test fields for fuel cell, electric motor and battery can be operated separately for DUT testing simulating the powertrain behavior with the electrical infrastructure. In addition, flexible coupling of the test fields in up to 16 different use cases is possible allowing the experimental investigation of interactions between the components in the electrical HV system and the performance of the overall powertrain system. A first-generation powertrain consisting of a multi-stack fuel cell system and an e-drive system with up to 1.2 MW of maximum power has been developed and implemented in the test facility. In order to evaluate the necessity and design of a potential support battery, the infrastructure provides the possibility of battery emulation during powertrain operation. First commissioning tests of the first-generation DUTs had been conducted at stationary power levels up to 600 kW. They proof the operability of the test facility and the first-generation fuel cell and e-drive system at least at part loads.

#### Acknowledgements

This work was supported by the Federal Ministry of Digital and Transport of Germany as part of the National Hydrogen and Fuel Cell Technology Innovation Program (NIP) (research projects BALIS, 03B10705 and BALIS 2.0, 03B10708C). The authors thank their colleagues Marco Richter, Pascal Hirth, and Timo Braun for their technical work in setting-up the test fields and during

commissioning. The support of the project teams of AVL, Power Cell and Compact Dynamics is gratefully acknowledged.

#### References

- [1] International Air Transport Association (IATA), *Aircraft Technology Roadmap to 2050* (2019), Geneva, Switzerland.
- [2] International Air Transport Association (IATA), *Aircraft Technology: Net Zero Roadmap* (2024), Montreal/Quebec, Canada.
- [3] Air Transport Action Group (ATAG), *Waypoint 2050: Balancing growth in connectivity with a comprehensive global air transport response to the climate emergency: a vision of net-zero aviation by mid-century* (2021) Geneva, Switzerland.
- [4] N. Lapeña-Rey, J. Mosquera, E. Bataller, F. Ortí J. *Aircraft* 47 (2010) 1825.
- [5] Deutsches Zentrum für Luft- und Raumfahrt e.V. (DLR), *Press Release: DLR Motor Glider Antares Takes off in Hamburg powered by a Fuel Cell* (2009) Stuttgart, Germany.
- [6] G. Romeo, F. Boello, G. Correa, E. Cestino *Int. J. Hydrogen Energy* 38 (2013) 469.
- [7] S. Flade, T. Stephan, O. Thalau, T. Burberg, J. Schirmer, J. Kallo *ECS Transactions* 74 (2016) 471.
- [8] ZeroAvia, *Press Release: ZeroAvia Conducts UK's First Commercial-Scale Electric Flight* (2020) Cranfield, United Kingdom.
- [9] H2Fly, *Press Release: H2FLY And Partners Complete World's First Piloted Flight of Liquid Hydrogen Powered Electric Aircraft* (2023) Stuttgart, Germany & Maribor, Slovenia.
- [10] ZeroAvia, *Press Release: ZeroAvia Successfully Completes Initial Dornier 228 Flight Test Campaign* (2023) Kemble, United Kingdom & Hollister, USA.
- [11] A. Baroutaji, T. Wilberforce, M. Ramadan, A. G. Olabi *Renew. Sustain. Energy Rev.* 106 (2019) 31.
- [12] S. Kazula, S. de Graaf, L. Enghardt *J. Glob. Power Propuls. Soc.* 7 (2023) 43.
- [13] T. Jamal, G. M. Shafiullah, F. Dawood, A. Kaur, M. T. Arif, R. Pugazhendhi, R. M. Elavarasan, S. F. Ahmed *Energy Rep.* 10 (2023) 2103.
- [14] Universal Hydrogen, *Press Release: Universal Hydrogen Successfully Completes First Flight of Hydrogen Regional Airliner* (2023) Los Angeles & Moses Lake, USA.
- [15] Airbus, *First ZEROe engine fuel cell successfully powers on*, January 16, 2024, Available from: <https://www.airbus.com/en/newsroom/stories/2024-01-first-zeroe-engine-fuel-cell-successfully-powers-on> (downloaded at 18 September 2024).
- [16] S. Campanari, G. Guandalini, J. Coolegem, J. ten Have, P. Hayes, A. H. Pichel *J. Electrochem. En. Conv. Stor.* 16 (2019) 041001-1.
- [17] E. Crespi, G. Guandalini, S. Gößling, S. Campanari *Int. J. Hydrogen Energy* 46 (2021) 13190.
- [18] L. Fan, Z. Tu, S. H. Chan *Energy* 257 (2022) 124728.
- [19] L. Fan, Z. Tu, X. Luo, S. H. Chan *Int. J. Hydrogen Energy* 47 (2022) 4033.
- [20] J. Fritz, C. Bänsch, J. Weiss, G. Hacker, D. Diarra, C. Bever, I. Thiele *Systems Engineering Methodology on a Multi-Integration Test Environment for Fuel Cell Flight Propulsion Systems*, Deutscher Luft- und Raumfahrtkongress (2022), Deutsche Gesellschaft für Luft- und Raumfahrt - Lilienthal-Oberth e.V.,

Dresden, Germany, DOI: 10.25967/570366.

- [21] S. Zhou, L. Fan, G. Zhang, J. Gao, Y. Lu, P. Zhao, C. Wen, L. Shi, Z. Hu *Appl. Energy* 310 (2022) 118555.
- [22] C. Rocha, T. Knöri, P. Ribeirinha, P. Gazdzicki *Renew. Sustain. Energy Rev.* 192 (2024) 114198.
- [23] X. Zhang, C. L. Bowman, T. C. O'Connell, K. S. Haran *IET Electr. Power. App.* 12 (2018) 767.
- [24] R. C. Bolam, Y. Vagapov, A. Anuchin A Review of Electrical Motor Topologies for Aircraft Propulsion, 55th International Universities Power Engineering Conference (2020), Turin, Italy, DOI: 10.1109/UPEC49904.2020.9209783.
- [25] A. Oubelaid, N.Khosravi, Y. Belkier, N. Taib, T. Rekinoua, *J. Energy Storage* 68 (2023)107676.
- [26] T. Kadyk, R. Schenkendorf, S. Hawner, B. Yildiz, and U. Römer, *Front. Energy. Res.* 2019, 7, 35.